

OWNER'S MANUAL

English

SERIES: "FALCON"

MODELS: **F300, F330, F360**
(F300H*, F330H*, F360H*)

Deluxe version: F300L, F330L, F360L
Sport version: F300S, F330S, F360S
Tender Deluxe version: F300T, F330T, F360T

2385.01-2014

H* – boat tube is made of HYPALON (Du Pont registered trademark) coated fabrics.

CONTENTS:

DANGER LEVELS	3
INTRODUCTION	3
IDENTIFICATION PLATE	4
SAFETY REGULATIONS	5
BEAUFORT Wind Scale and Corresponding State of the Sea, After Few Hours of Wind, Away From the Coast.	6
Boat Design Categories	6
REMEMBER FIRE DANGER ALWAYS	7
TECHNICAL SPECIFICATIONS	8
COMPLETE SET	9
GENERAL VIEW of the BOATS	10
STEERING CONSOLE	
Steering Console for DeLuxe and Tender Deluxe Versions	12
Tender Container for DeLuxe and Tender Deluxe Versions	14
Steering Console for Sport Version	15
Inflation/deflation boat tube	16
PREPARATION FOR EXPLOITATION	17
DRAIN SYSTEM	17
REMOVABLE FUEL TANK	18
MAINTENANCE	19
OPERATING REGULATIONS	19

CE Certification and Main Features

The CE marking indicates that the inflatable boat was built in compliance with the Directive 94/25/EC applied to pleasure craft

Certifying Body:



BUREAU VERITAS S.A.
92077 Paris La Defense Cedex

Name of Manufacturer:

BRIG Ltd.
Lozovskaya 88, Dergachy
62303
Kharkovskaya obl.
UKRAINE
www.brig-ribs.com

DANGER LEVELS.

The manual contains warnings, identified as follows:

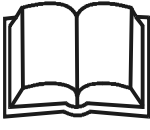
 DANGER	A note like this indicates that there is serious risk that is likely to cause death or permanent serious injury, if appropriate precautions are not taken.
 WARNING	A note like this indicates the existence of risk that may cause death or injury, if appropriate precautions are not taken.
 ATTENTION	A note like this indicates reference to the application of safety or environmental protection practices, or draws attention to unsafe behaviour that might cause injury to persons or damage to the craft, its components or the environment.

INTRODUCTION.

This manual was written to help you using your boat safely. It contains information of the boat, its equipments (supplied or installed), operation and maintenance.

 DANGER	Before using your boat, read the MANUAL carefully and ensure that you have understood all the procedures it describes. Before taking command of your boat, be sure to have acquired experience and confidence in its operation.
--	---

IDENTIFICATION PLATE.

Builder's Plate:

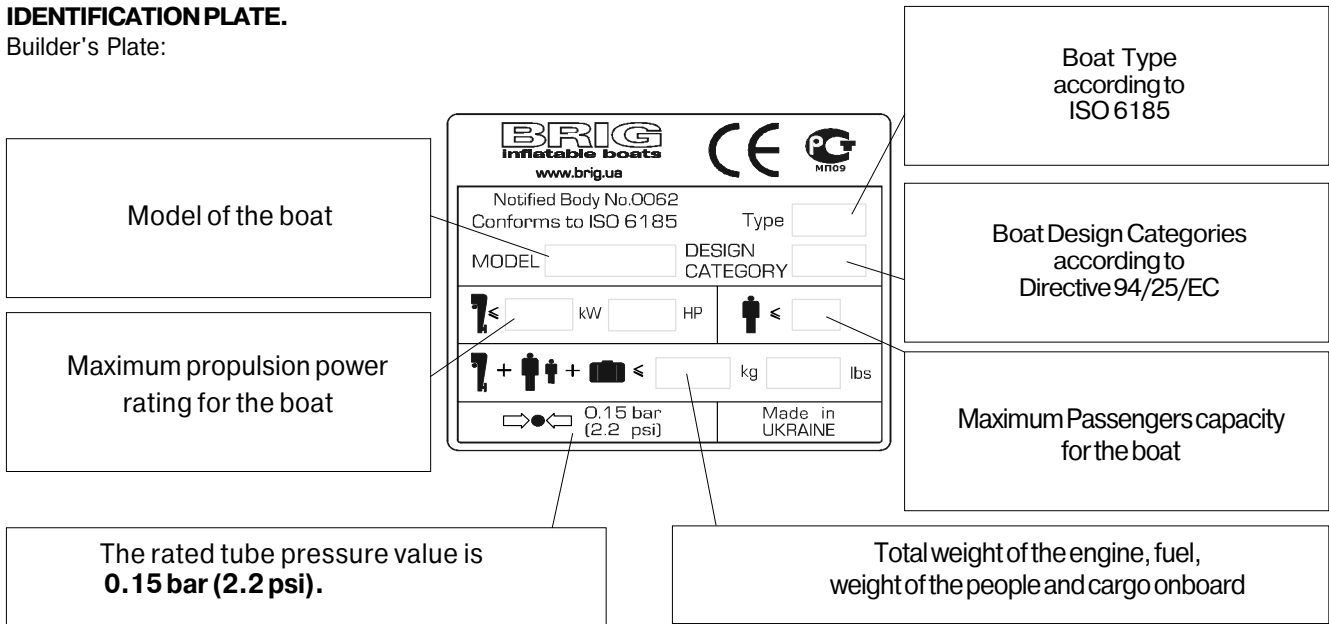
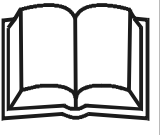

Plate with identification number:

UA-QRK12345A000





ATTENTION

It is fundamental for the plates to be aboard the boat, since they are only form of recognition and identification. Without them the boat does not comply with the legislation in effect. The plates must never be removed. Any tampering or removal not authorised by the manufacturer is the full responsibility of the owner.

SAFETY REGULATIONS.

This manual contains recommendations and basic rules of conduct for using the boat in complete safety. Although it is not possible to offer safety information for all potential situations, in general it is recommended that you:

	Regularly check which safety requirements are in force.
	Maintain the boat and the onboard plants in optimum condition.
	Have the boat inspected by the dealer where it was purchased or by an authorised machanic at least once every year for your own safety and for maintaining the guarantee.

	Always check weather and seagoing conditions before setting out. For safe navigation, compare the design category of your boat with the table below.
	When the tank is installed by the yard, the plant is prepared with a ground plait. The installation of the motor MUST FORESEE A PLAINT CONNECTION to the boat ground plait. Failure to connect (or failed maintenance) can result in the tank perforaiting leading to a serious risk of fire / explosion caused by leaking fuel.

	<p>Max number of transportable persones is referred to an established weight of 75 kg per person (ISO 6185), so always make reference to total maximum transportable waight.</p> <p>The max weight of the installable motors indicates the maximum overall weight applicable on the stern board, including any emergency motors. NEVER exceed the stated value.</p>
---	--

BEAUFORT Wind Scale and Corresponding State of the Sea, After Few Hours of Wind, Away From the Coast.

Force	Denomination	Knots	Km/h	m/sec	State of the sea and wave height in meters	
0	Calm	<1	<1	0-0.2	Calm	0
1	Light Air	1-3	1-5	0.3-1.5	Calm	0
2	Light Breeze	4-6	6-11	1.6-3.3	Almost calm	0.2
3	Gentle Breez	7-10	12-19	3.4-5.4	Almost calm	0.2
4	Moderate Breeze	11-16	20-28	5.5-7.9	Small waves	0.5
5	Strong Breeze	17-21	29-38	8.0-10.7	Large waves	1.25
6	Fresh Wind	22-27	39-49	10.8-13.8	Large waves	2.0
7	Strong Wind	28-33	50-61	13.9-17.1	Very large waves	2.5
8	Gale	34-40	62-74	17.2-20.7	Rough sea	4
9	Strong Gale	41-47	75-88	20.8-24.4	Very rough sea	6
10	Storm	48-55	89-102	24.5-28.4	Heavy	9
11	Violent Storm	56-63	103-117	28.5-32.6	Very heavy	14
12	Hurricane	64 and over	118 and over	32.7and over	Stormy	14 and over

Boat Design Categories (Directive 2003/44/EC):

Design category	Wind force (Beaufort scale)	Significant wave height
"A" - "Ocean"	exceeding 8	exceeding 4
"B" - "Offshore"	up to, and including, 8	up to, and including, 4
"C" - "Inshore"	up to, and including, 6	up to, and including, 2
"D" - "Sheltered waters"	up to, and including, 4	up to, and including, 0.3

NOTE: **The significant wave height** is the mean height of the highest one-third of the waves, which approximately corresponds to the wave height estimated by an experienced observer. Some waves will be double this height.

REMEMBER FIRE DANGER ALWAYS.

Fire may be caused by:

Crew negligence when smoking, the presence aboard of flammable liquids, electrical contacts, propulsion motor, errors in fueling, or if maintenance has not been performed as required.

Once again, it is important that the crew behave correctly and that the boat is kept in order to avoid serious damage to it and to persons.

 WARNING	Easily flammable products must not be kept aboard.
---	--

 DANGER	BATTERY: the battery may cause sparks or explosions. It must be stored in an appropriate container, easily reached and well aired, AWAY FROM FUEL OR INFLAMMABLE PRODUCTS. Periodically check that the clips are tight and protect them with appropriate insulation in order to prevent sparks or the spread of current.
--	--

However, if a fire does occur aboard, stop motor, disconnect the batteries immediately, check to see if it is an electrical component or any case a small-scale fire that does not involve flammable liquids, in which case use a suitable fire extinguisher to try and put the fire out completely.

 WARNING	Extinguisher or any other fire-fighting equipment must not be kept in compartments with key lock, but in easily accessible and clearly indicated locations. Extinguisher or any other fire-fighting equipment should be checked periodically and replaced with the same or superior types if expired or inefficient.
---	--

 DANGER	Equip the boat with fire-fighting equipment before launch and use.
--	--

TECHNICAL SPECIFICATIONS.

"BRIG" inflatable boat of the "FALCON" series fulfills the requirements of conformity to the essential requirements of the Directive 94/25/EC and ISO 6185-3.

The basic parameters and dimensions of the boats comply with the data specified in the following table:

Parameter	Unit of measure	F300			F330			F360		
		F300L	F300S	F300T	F330L	F330S	F330T	F360L	F360S	F360T
Length (without engine)	m	3.00	3.00	2.90	3.30	3.30	3.20	3.60	3.60	3.50
Width	m		1.64			1.64			1.75	
Inflatable tube diameter	m		0.40			0.40			0.45	
Cockpit dimensions:										
- length	m		2.00			2.22			2.52	
- width	m		0.84			0.84			0.78	
Number of independent air-tight chambers	pcs.		3			3			3	
Nominal pressure	BAR (psi)		0.15 (2.2)			0.15 (2.2)			0.15 (2.2)	
Carrying capacity (ISO method)	kg		500			550			600	
Passengers capacity	men		4			4			5	
Recommended engine power	HP		4-15			5-20			10-30	
Maximum engine power	HP		20			25			35	
Maximum engine weight	kg		54			73			95	
Engine shaft length	inches		short / 15			short / 15			short / 15	
Weight of empty boat (without engine)	kg	87	92	100	97	102	115	112	117	130
Weight of boat with MAX engine	kg	141	146	154	170	175	188	207	212	225
Maximum transportable mass	kg		265			325			315	
Loaded displacement mass	kg		565			625			690	
Design category (94/25/EC)			C			C			C	

COMPLETE SET for Deluxe, Sport and Tender Deluxe versions.

No		Deluxe version	Sport version	Tender Deluxe version
	Package No1			
1.	Inflatable boat	+	+	+
2.	Front step-plate with navigation lights	-	-	+
3.	Hard tube ends	-	-	+
4.	Front removable cushion (excluding F300)	+	-	+
5.	Foot pump	+	+	+
6.	Paddle	+	+	+
7.	Set of spare parts and repair kit (mooring line, coated fabric for repair, glue set for repair)	+	+	+
8.	Kit bag	+	+	+
9.	Owner's manual	+	+	+
	Package No2 (carton)			
1.	"SPORT" console	-	+	-
2.	Tender Luxe Console	+	-	+
3.	Steering wheel, steering system with cable	+	+	+
4.	Bolts for console installation	+	+	+
	Package No3 (carton)			
1.	Tender Container	+	-	+
2.	Bolts for container installation	+	-	+
	Optional equipments			
1.	Overall cover	+	+	+
2.	Overall cover for "SPORT" console	-	+	-
3.	Suntop (excluding F300)	+	+	+
4.	Bow stowage bag	+	+	+

Note. Perfection of the design and improvement of quality of our products is the fundamental production policy of our company. Therefore, alternations may be made to the complete set (and as the components become available).

GENERAL VIEW of the BOATS.

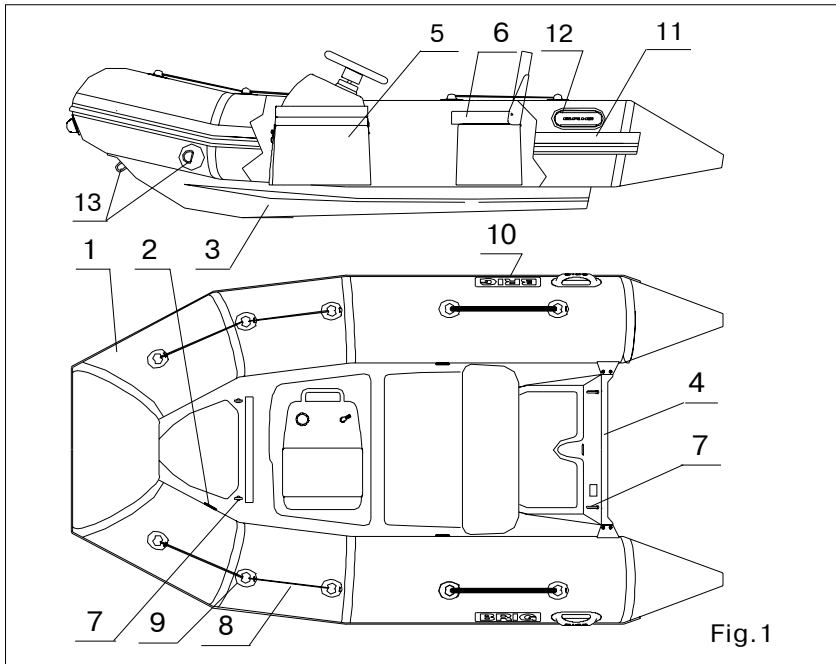

DELUXE version Boat General View (see Fig. 1).

- 1 - Inflatable tube
- 2 - Inflation valve
- 3 - Rigid bottom with transom
- 4 - Outboard engine mounting plate
- 5 - Tender luxe console
- 6 - Tender container
- 7 - Lifting bow eye
- 8 - Lifeline
- 9 - Lifeline holder
- 10 - "BRIG" label
- 11 - Rubbing strake
- 12 - Carrying handle
- 13 - Towing bow eye

Fig. 1

SPORT version Boat General View (see Fig.2).

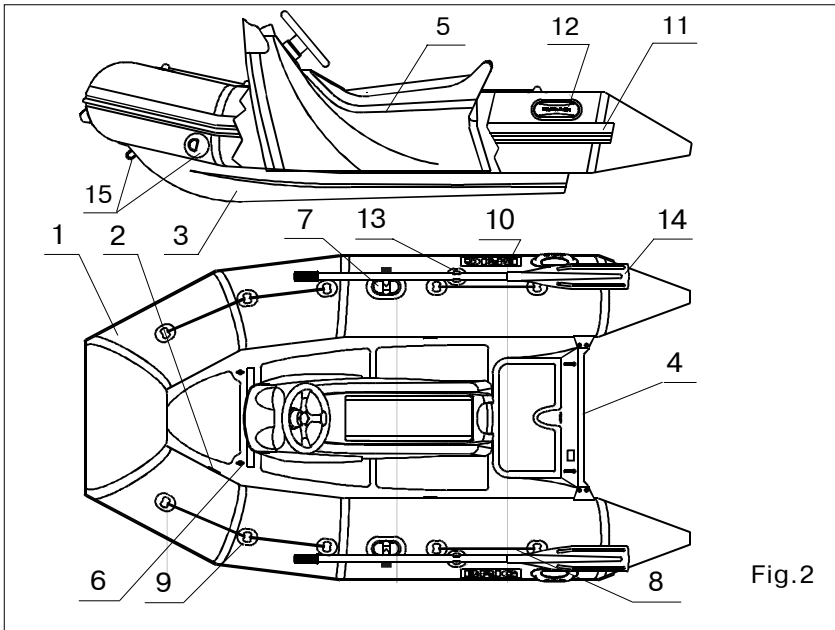

- 1 - Inflatable tube
- 2 - Inflation valve
- 3 - Rigid bottom with transom
- 4 - Outboard engine mountingplate
- 5 - Sport console
- 6 - Lifting bow eye
- 7 - Rowlock
- 8 - Lifeline
- 9 - Lifeline holder
- 10 - "BRIG" label
- 11 - Rubbing strake
- 12 - Carrying handle
- 13 - Oar stowage
- 14 - Oar
- 15 - Towing bow eye

Fig.2

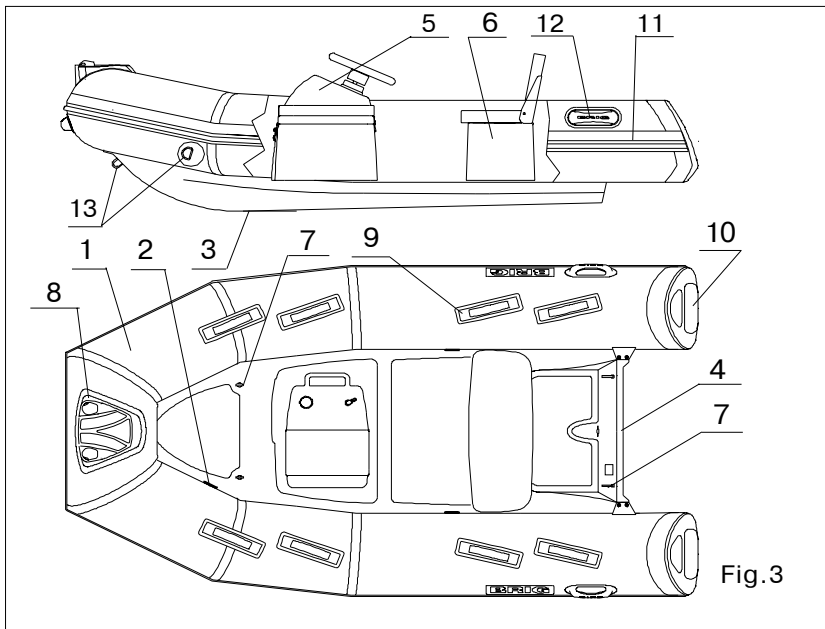

TENDER DELUXE version Boat General View (see Fig.3).

- 1 - Inflatable tube
- 2 - Inflation valve
- 3 - Rigid bottom with transom
- 4 - Outboard engine mountingplate
- 5 - Tender luxe console
- 6 - Tender container
- 7 - Lifting bow eye
- 8 - Bow stop plate with navigation lights
- 9 - Handle
- 10 - Hard tube end
- 11 - Rubbing strake
- 12 - Carrying handle
- 13 - Towing bow eye

Fig.3

STEERING CONSOLE.

Steering Console for DeLuxe and Tender Deluxe Versions.

Steering console Tender Luxe is intended for mounting steering system and remote control system.

The console may be installed on the BRIG boats F300, F330 and F360 Deluxe and Tender Deluxe versions.

The Steering console consists of the following main components (Fig.4):

- console body, that comprises the overhead part (2), hinged with lower part (1).
- cushion (3);
- lock (4);
- wire type steering grommet (5).

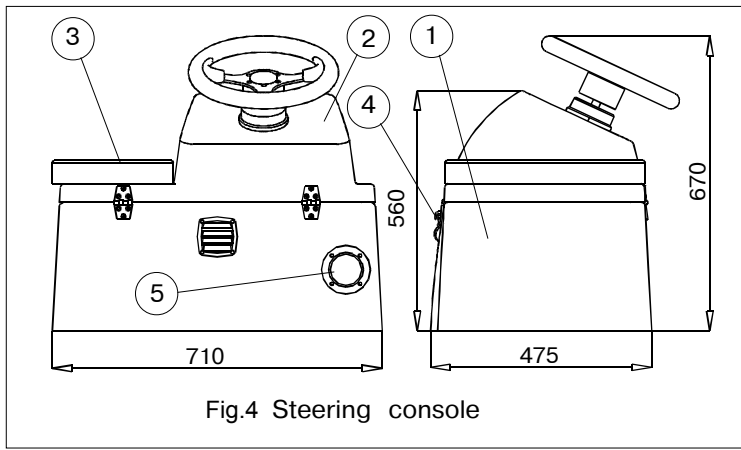

Fig.4 Steering console

In order to install the console to the BRIG boat perform the next operations (Fig. 5):

- hinge out the overhead console part;
- fix the console by means of the bolt M8x25 and washers to the deck boat;
- replace the console overhead part;

You can use inside compartment of the console as locker. Also you can dispose fuel tank (25L max) inside console (Fig.6). In this case you must fixed safely fuel tank by belt.

If you need less height of console, you can reduce it. Hinge out the overhead console part and her height will be 485mm (Fig.6).

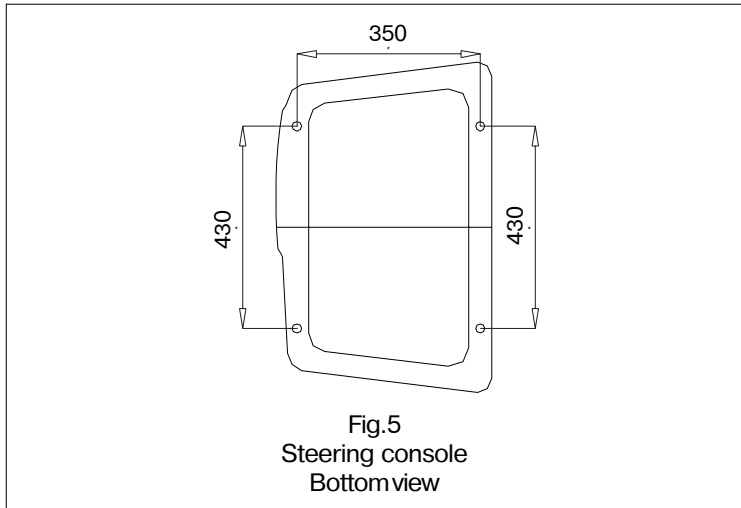

Fig.5
Steering console
Bottom view

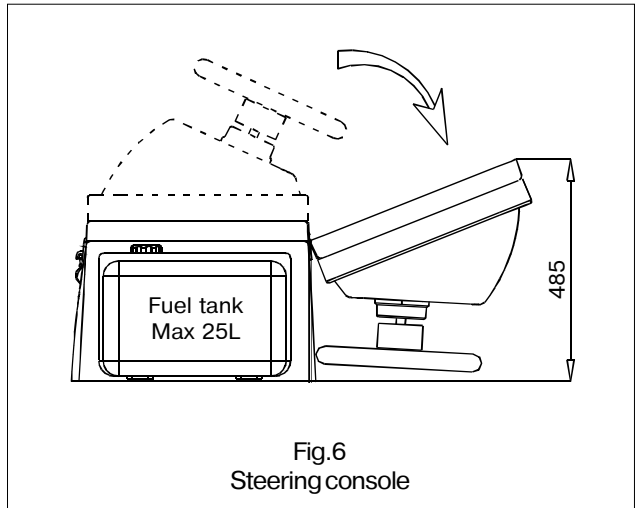

Fig.6
Steering console

Tender Container for DeLuxe and Tender Deluxe Versions.

Tender Container is intended for placing of two passengers and for installation of storage battery, oars etc.

They may be mounted on the rigid deck of the "BRIG" boats F300, F330, F360 Deluxe and Tender Deluxe versions and other boats.

Tender Container includes: the locker, soft seat and lock to fixing the seat (see Fig.7).

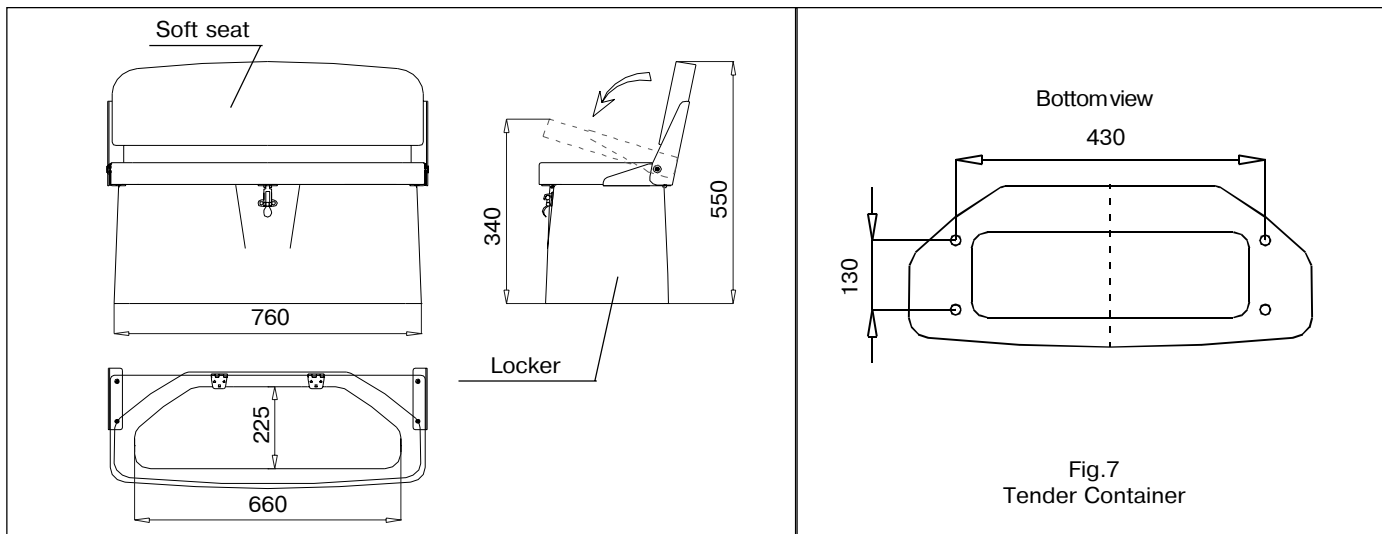
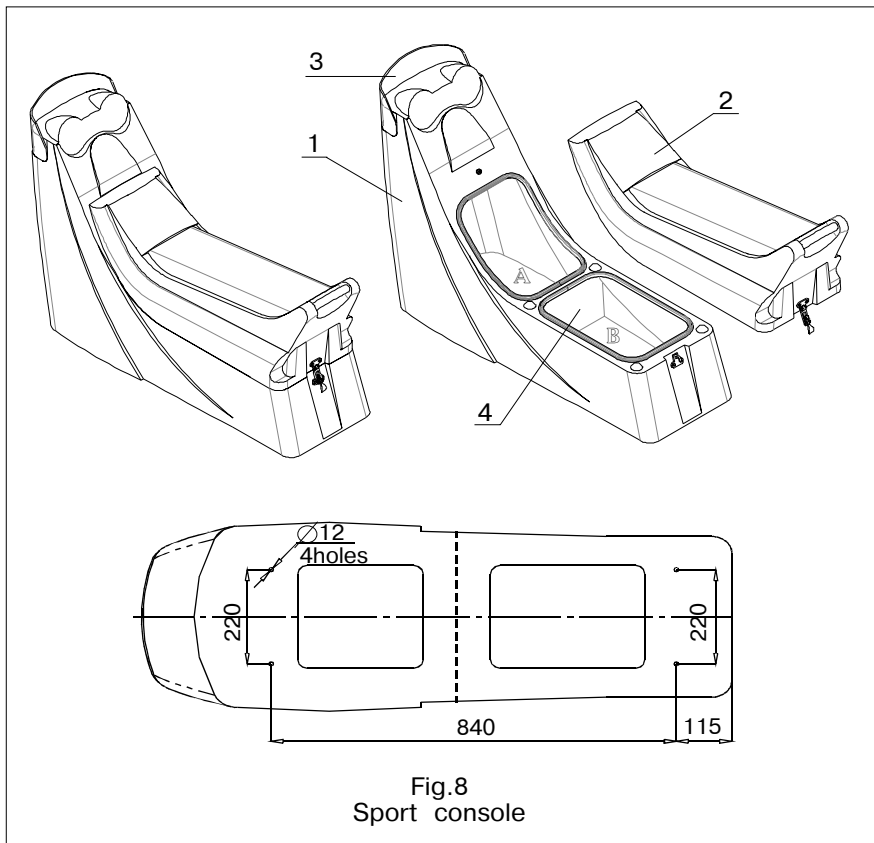

Fig.7
Tender Container

In order to install the container to the BRIG boat perform the next operations (see Fig. 7):

- hinge out the seat;
- fix the container by means of the bolt M8x25 and washers to the deck boat;
- replace the seat.

Steering Console for Sport Version.



Console SPORT general view is shown in the Fig.8:

- 1.The console body.
- 2.The upper removable part with seat.
- 3.The windscreen.
- 4.The interior wall.

The interior wall divides the inner volume of the console body into two compartments. The compartment A is recommended for the installation of the storage battery, the compartment B has been designed for the installation of the standard fuel tank (12L max).

In order to install the console to the BRIG boat perform the next operations (Fig. 8):

- disconnect the upper removable part with seat;
- fix the console by means of the bolt M8x25 and washers to the deck boat;
- replace the upper removable part with seat.

Inflation/deflation boat tube.

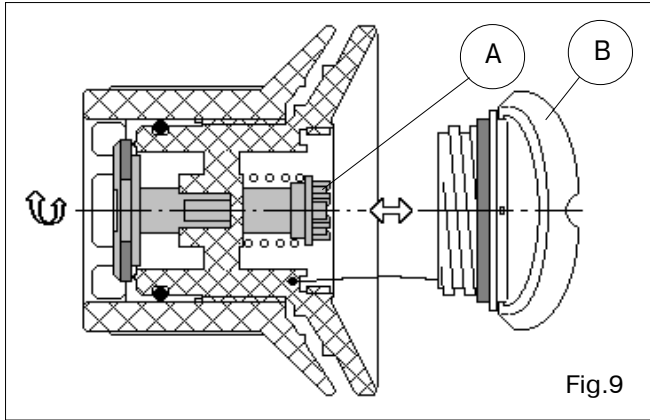

Fig.9

The inflation valve (see Fig.9) has two positions of sliding part A corresponding to its two conditions (modes):

- sliding part A is withdrawn - operation condition of the valve (compartment air filling mode);
- sliding part A is recessed - valve in condition "OPEN" (compartment air discharge mode).

In order to switch the valve over from one condition to another, just press sliding part A with your finger to turn it by 90 degrees in any direction until it is fixed.

Prior to begin the compartment filling process set all valves in the operating condition. On completion of filling close the valves with bonnets B (rotate them clockwise).

In order to discharge air from the compartments, open the valves (by counterclockwise rotation) and switch the valves over into condition "OPEN".

 WARNING	Do not use compressors and/or other types of inflating equipments not approved by the boat builder.
	Check tube pressure before every navigation.
	<p>The rated pressure value is 0.15 bar (2.2 psi).</p> <p>If the tube pressure more than nominal, deflate the compartments slightly. Boat exploitation with board pressure more than nominal decreases boat service life.</p>

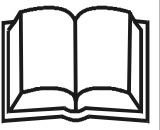
 ATTENTION	Board air chambers are hermetical if they keep own form during 8 hours. In this case:
	<ul style="list-style-type: none"> - primary pressure has to be nominal; - input valves openings have to be tightly closed by caps.

PREPARATION FOR EXPLOITATION.

In order to set the boat in the operation condition perform as follows:

Unfold the inflatable balloon.

Apply the foot pump to fill the afterbody of the compartments with air to the pressure being slightly below its rated value (the balloon will be completely straightened). Then fill the forebody compartment with air up to the rated pressure.

The rated pressure value is 0.15 bar (2.2 pci).

On completion of filling close the valves with bonnets B (rotate them clockwise), (look before).

Assemble the oars by entering the removable parts with blades into the locks until the click. Make use of the holes provided in the oar handles to set the oars into the rowlocks with the blades being faced to the aft. Secure the oars in the holders.

When mounting the outboard engine make sure that it is reliably fixed to the transom. In addition, take every precaution to avoid any contacts of the fuel with the boat surfaces.

DRAIN SYSTEM.

1 - Drain valve for cockpit water
(see Fig.10)

2 - Drain valve for bilge water

It is dangerous to pretend to be an expert. This may cause damages. Refer to expert and authorized specialists for all types of maintenance and repair.



Check before navigation that that the drain valve for bilge water is closed by plug. Open to pour out the bilge water (! ashore ONLY !)

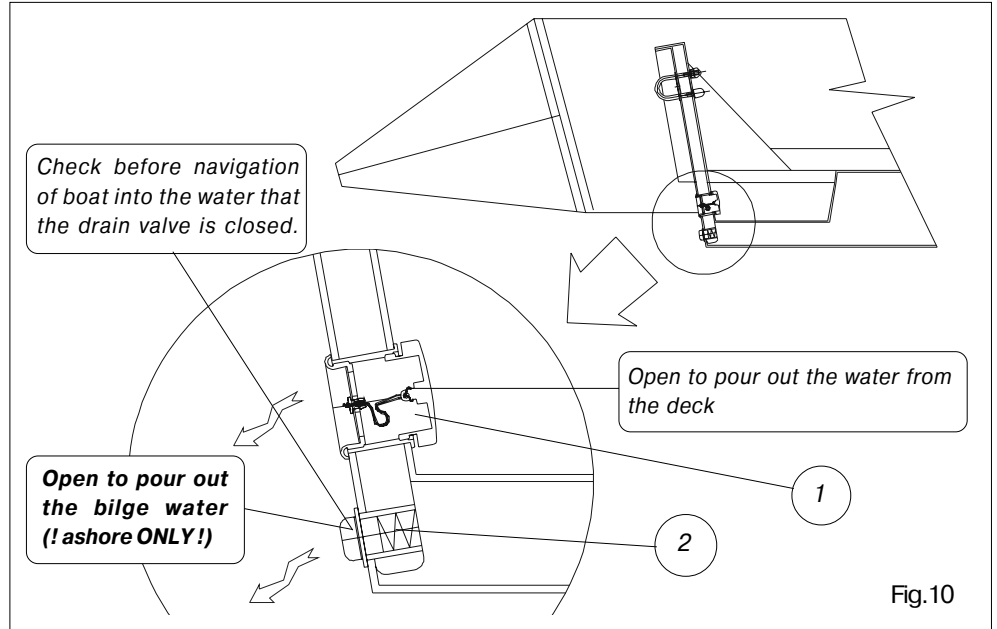



REMOVABLE FUEL TANK.

The recommended position on board for install of removable fuel tank is following:

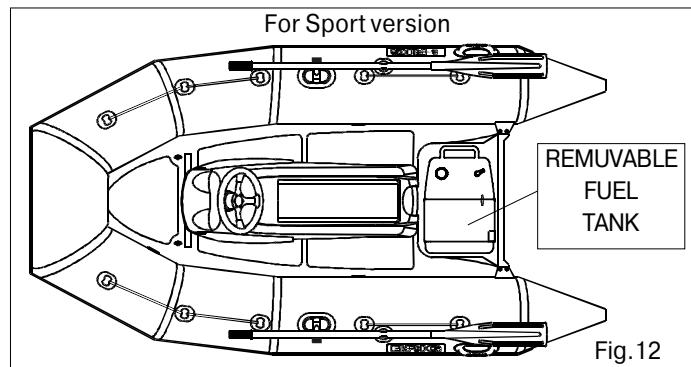
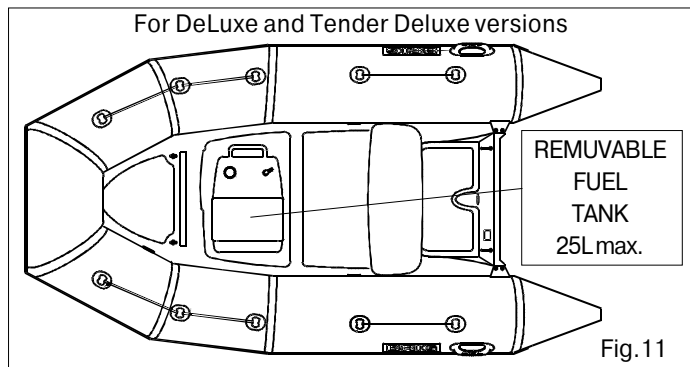
- for DeLuxe and Tender Deluxe versions - inside the Tender console (fuel tank 25L max) (see Fig.11)
- for Sport version - on the rear part of the boat (see. Fig.12) or inside the Sport console.



 WARNING	Do not begin navigation without checking that the fixing of the fuel tank is tightened safely.
 DANGER	Check that there are no leaks in the fuel systems
 WARNING	Do not smoke when refueling. Stop the engine and switch off any electric equipments before refueling.

MAINTENANCE.

- Main conditions of long service life is right and careful servicing. Avoid excessive increasing of pressure in the board, especially from heating by the sun rays.
 - After exploitation take off sand and dirt from boat surface, and carefully dry it.
 - Avoid the water getting into the chambers. If a fuel or an oil gets to the boat surface it is necessary to wash the soiling place by soap water as soon as possible and dry.
 - Pay attention to the condition of bottom surfaces. If it's cover is destroyed it is necessary to dry this element and restore the defend cover.
 - After season prepare the boat to winter keeping. Clean boat surface from sand and dirt and make the necessary repairs, if damages take place. If it is possible, keep the boat in the open and slightly pumped state in air temperature 0-25°C. The boat must be protected from the sun rays.
 - Insignificant boat repairing (eliminating the board punctures or cuts) you may carry out by yourself. In this case use the coated fabric and glue set for repair from the complete set.
- Independent performance of any complex repair associated with considerable damages to the board, partitions and seams is not recommended. In such cases, apply to your dealer.



Storage of the boat with temperature variations from -30°C to +45°C may be allowed for not longer than 1 month.
In case the boat has being stored or transported at a temperature bellow 0°C, it must be held at a temperature above +15°C for at least 1 hour before be unpacked and unfolded.

For small repair boat tube use the coated fabric and glue set from the complete set.

OPERATING REGULATIONS.





Dear user,





We thank your for your purchase and do hope that you will have a great fun of it. However, to make your joy and pleasure complete, we would request you to read carefully and observe the directions and recommendations specified below.



IT IS STRICTLY FORBIDDEN to handle the boat in the state of intoxication and without individual rescue means being used (life-saving belts, jackets, etc.)

IT IS FORBIDDEN to use an outboard engine of power exceeding the maximum allowable value

 WARNING	IT IS FORBIDDEN to bring the tube pressure up to the value exceeding the rated one (0.15 bar(2.2pci))
	IT IS STRICTLY FORBIDDEN to drag the boat across a rough surface.
	For each particular water area the local shipping regulations are in force. You may apply for information to the appropriate water transport and shipping directorate, as well as to the water police.
 WARNING	Use the boat equipment and accessories only on their direct purpose to ensure reliable service.
	Even when sailing with an outboard engine you should always have the oars available with you so that you were able to reach the shore without outside assistance in case of any damage to the boat.
 WARNING	On your request any outboard engine seller may provide your engine with the emergency stop switch. During navigation the switch should be connected to the wrist of your hand by means of a cord. In case you fall overboard, even if being a steersman, the switch will cut out the engine and the propeller. This arrangement will enable you to avoid any traumas and to reach the boat.
	Take all possible precautions against penetration of fuel, oil or electrolyte from the storage battery into the inflatable boat. If it does happen wash thoroughly the fouled spots with water.
 DANGER	You should be always sure that the number of people on board never exceeds that specified in the owner's manual or on the builder's plate provided on the transom.
	The boat will retain an adequate floatability and will not keel over only provided that the load is arranged reasonably. Therefore, do not accommodate all passengers on the same side of the boat.
 DANGER	All passengers should be accommodated inside the boat. The occupied seats should not be left throughout the entire sailing time.

 <p>DANGER</p>	<p>All passengers should put on life-saving jackets</p> <p>CHILDREN and non-swimmers MUST BE A FLOATATION DEVICE AT ALL TIMES.</p> <p>Always check that floatation devices for children are of the right size and that they are operational.</p>
 <p>DANGER</p>	<p>Arrange the cargo to be carried uniformly inside the boat, all items being reliably secured on the bottom of the boat.</p> <p>When sailing with an outboard engine the steersman should shift his body forward in the course of acceleration to prevent the boat forebody from raising under the force of upthrust waves.</p>
 <p>WARNING</p>	<p>Despite the strong shell of the boat we are recommended to handle sharp and pricking objects being on board with care. For example, it concerns a knife blade, fish-hook point, etc.</p>
 <p>DANGER</p>	<p>Approach rocky shores, shoals, moles, etc. carefully to avoid damages to the boat. It is strictly prohibited to drag the boat across rough surfaces (shingle, rocks, concrete, etc.).</p> <p>In case of prolonged navigation with the use of an outboard engine, regularly check to ensure that the engine is reliably attached to the boat. If the engine was attached carelessly the attachment may work loose under the action of vibration.</p>
 <p>WARNING</p>	<p>Besides, check air chambers pressure at regular intervals, since the pressure may vary under the effects of outside air temperature and atmospheric pressure variations.</p> <p>Never forget to monitor regularly the quantity of fuel in the fuel tank. Keep always in mind that the quantity of fuel should be sufficient for you to sail to your final destination.</p>

● **Towing**

	At towing the towing rope length should not be at least 3 lengths of the boat.
	The steersman of the towed boat should be assisted by another crew member to monitor the process of towing. In this case, certain communication gestures should be agreed upon beforehand.

	The rope being secured to both boats in a manner ensuring its immediately, single-motion release.
---	---

● **Damage to one of air chambers**

The inflatable boat is designed to provide an adequate stability in case of the complete damage to one the air chambers (balloon compartments) at the expense of the remaining air chambers and the hull. Thanks to it, you will be able to reach safely the nearest shore. Reduce the speed and shift your body to the undamaged part of the boat. Watch changes in stability. After this immediately head for the nearest shore. To prevent penetration of water into the boat, pull the shell of the damaged air chambers upwards.

● **Anchor and mooring fast fastening**

	Fix the anchor and towing ropes in the bow of the boat to the front towing ring. Fix the back anchor ropes to the back towing ring.
---	---



● **Danger of currents and wind**

	Before navigation of the boat make detail inquiries about local conditions and regulations! Currents, wind, shoals, rising and falling tides, as well as weather variations may imply serious danger!
--	---

● **In emergency stay in boat**

In any unexpected situation (engine failure, boat damage, etc.) do not ever leave the boat provided it is still afloat. Even if you believe that the shore is just nearby stay in the boat, since you will be looked for in this particular place and, most probably, will be found. Should the boat become partially flooded throw heavy objects (batteries, fuel tank, engine) overboard to ensure additional floatability.

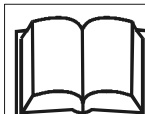
● **Handling under power**

 <p>WARNING</p>	<p>Manoeuvrability above 4knots (7.4 km/h) is limited. Sudden turn may cause loss of control. Reduce speed before making sharp in either direction.</p>
 <p>ATTENTION</p>	<p>Maximum propulsion power rating for the boats:</p> <p style="text-align: center;">F300-14.7 kW (20 HP) F330-18.4 kW (25 HP) F360-25.7 kW (35 HP)</p>
 <p>WARNING</p>	<p>Do not operate your boat with an engine of rated power larger than that posted on the builder's plate in the boat.</p>
 <p>ATTENTION</p>	<p>Do not operate this craft at negative propulsion unit trim settings (bow down) at high speed. Craft may lean over on side. Instability in turns may result. Use negative trim to accelerate to planing speed from displacement speed and at lower planing speeds in choppy water (applicable to craft equipped with propulsion unit power trim).</p> <p>Do not operate at maximum speed while in congested high traffic waterways or in weather and sea conditions of reduced visibility high winds or large waves. Reduce speed and wake as a courtesy and as a safety consideration to yourself and others. Observe and obey speed limit and no wake zones.</p> <p>Observe right-of-way as defined by Rules of the Road and required by COLREG.</p> <p>Always be certain to have sufficient distance to stop or manoeuvre if required to avoid collisions.</p>

MODEL	<input type="text"/>
SERIAL No.	UA-QRK <input type="text"/>
Date of manufacture	<input type="text"/>
Quality inspection stamp	

NOTE: The inflatable boat was delivered with the following equipment installed:

1.Fuel tank	Stamp and signature	4.Steering system	Stamp and signature
2.Electric system	Stamp and signature	5.Engine power system	Stamp and signature
3.Drain system	Stamp and signature	6.Engine installation, test and completion of plants and fittings done by.	Stamp and signature